

**HOWDENS**  
JOINERY CO.

MAKING SPACE MORE VALUABLE

The Flooring Collection



Howdens Professional Continuous Light Stone Tile

## The Flooring Collection

### About Us

Howdens Joinery offers a range of joinery products and kitchens specifically designed for today's homes. We are a trade only business that has been selling to trade professionals since 1995. We believe that only experienced, qualified builders and joiners should install our products.

### Our Product Range

We offer a variety of flooring to suit every style and budget, from solid oak and laminate flooring to natural stone effect laminate tiles. Our range includes a choice of colours, such as oak, bamboo, American pecan and walnut, as well as different finishes, from timber effect to limestone and slate. Our selection also provides products suitable for a wide range of applications throughout the home and in commercial properties.

Howdens also supplies a variety of flooring accessories for a professionally fitted floor, including underlay, damp proof membrane, flooring spacers, colour-matched scotias, pipe roses and floor profiles.

### CAD Planning & Design Service

Howdens Joinery offers a free Computer Aided Design (CAD) planning and design service that features our full range of flooring. Contact your local trade professional who will arrange for one of our designers to come out and measure your room. They will discuss your requirements and our complete product offering.

### Our Commitment

We work closely with our suppliers to ensure that the items we purchase come from sustainable renewable resources and are produced in a socially responsible way. Howdens Joinery has successfully achieved the Forest Stewardship Council® (FSC®) and the Programme for the Endorsement of Forest Certification™ (PEFC™) Chain of Custody certificates, which apply to a number of products as indicated in this brochure by the FSC® logo or **F** and the PEFC™ logo or **P**. The Chain of Custody certification means there is an unbroken and documented chain of ownership all the way from the forest, via the mill, the importer, the manufacturer and the supplier to the end user. Our full environmental policy is available on request.

### UK Manufactured

A selection of flooring and flooring accessories are manufactured in the UK as indicated in this brochure by the **UK** or **UK MANUFACTURED** logo.

To find out more, contact your local builder or visit [www.howdens.com](http://www.howdens.com)



Howdens Professional Fast Fit V Groove Dark Grey Oak

## Contents

|   |           |
|---|-----------|
| <b>Howdens Flooring Overview</b>                    | <b>02</b> |
| <b>CAD Planning &amp; Design Service</b>            | <b>04</b> |
| <b>Flooring in your Home</b>                        | <b>05</b> |
| <b>Technical Flooring Guide</b>                     | <b>06</b> |
| <b>Howdens Solid Oak and Solid Bamboo Flooring</b>  | <b>11</b> |
| <b>Howdens Real Wood Flooring</b>                   | <b>13</b> |
| <b>Howdens Laminate Flooring</b>                    |           |
| Howdens Professional Fast Fit V Groove Flooring     | 15        |
| Howdens Professional Flooring                       | 19        |
| Howdens Original Flooring                           | 21        |
| Howdens Flooring                                    | 23        |
| Howdens Professional Continuous Tiles               | 25        |
| Howdens Professional Fast Fit V Groove Tiles        | 27        |
| Howdens Professional Random Effect Tile             | 28        |
| <b>Flooring Specifications</b>                      | <b>30</b> |
| <b>Flooring Care &amp; Maintenance Guide</b>        | <b>31</b> |
| <b>Flooring Accessories &amp; Tools</b>             | <b>32</b> |
| <b>Matching Flooring &amp; Worktop Combinations</b> | <b>38</b> |
| <b>Mouldings &amp; Scotias</b>                      | <b>40</b> |
| <b>The Complete Howdens Collection</b>              | <b>41</b> |

## Howdens Flooring Overview

---

Howdens Joinery offers a range of flooring solutions from solid wood through to timber and tile laminate.

### Howdens Solid Oak and Solid Bamboo Flooring - pg.11

---



Solid Oak  
(SDH3012/3062)  
(SDH3013)  
(SDH3063)



Solid Bamboo  
(SDH4310)

### Howdens Real Wood Flooring - pg.13

---



Oak Single Plank Wide  
(SDH3625)



Oak Single Plank  
(SDH3610)



Oak 3 Strip  
(SDH3215)

### Howdens Laminate Flooring

---

#### Howdens Professional Fast Fit V Groove Flooring - pg.15-17

---



Oak (Registered embossed)  
(SDH3525)



Rustic Oak (Registered embossed)  
(SDH3526)



American Pecan  
(SDH3528)

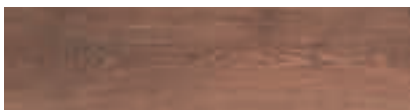

Chestnut Oak (Registered embossed)  
(SDH3529)

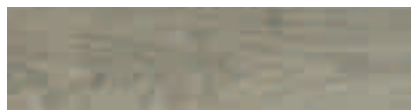

Dark Grey Oak  
(SDH3560)



Light Grey Oak (Registered embossed)  
(SDH3561)

#### Howdens Professional Flooring - pg.19

---



Oak  
(SDH3552)



Walnut  
(SDH3550)



Tudor Oak  
(SDH3551)

## Howdens Laminate Flooring

---

### Howdens Original Flooring - pg.21

---



Oak  
(SDH3565)



Dark Oak  
(SDH3567)

### Howdens Flooring - pg.23

---



Oak  
(SDH2096)



Rustic Oak  
(SDH2092)

### Howdens Professional Continuous Tiles - pg.25

---



Natural Stone (Registered embossed)  
(SDH2082)



Black Slate (Registered embossed)  
(SDH2084)



Limestone (Registered embossed)  
(SDH2083)



Light Stone (Registered embossed)  
(SDH2088)

### Howdens Professional Fast Fit V Groove Tiles - pg.27

---

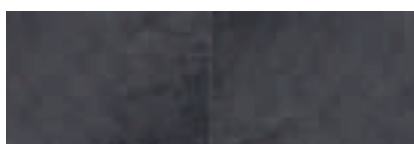

Basalt Slate  
(SDH3662)



Travertine  
(SDH3663)

### Howdens Professional Random Effect Tile - pg.28

---



Slate  
(SDH3650)

## CAD Planning & Design Service

---

Howdens Joinery offers a free Computer Aided Design (CAD) planning and design service that features our full range of flooring.

Contact your local trade professional who will arrange for one of our designers to come out and measure your room. They will discuss your requirements and our complete product offering.



Howdens Solid Bamboo



Howdens Professional Fast Fit V Groove Rustic Oak



Howdens Original Dark Oak



Howdens Professional Fast Fit V Groove Basalt Slate Tile



## Flooring in your Home

---

We offer flooring solutions for every room in the home, including the kitchen, hallway, living room, dining area, bedroom and bathroom.

Our complete range of flooring includes solid wood, timber laminate and tile laminate, as well as a variety of flooring accessories for a professionally fitted floor.



Kitchen



Hallway



Living Room



Dining Area



Bedroom

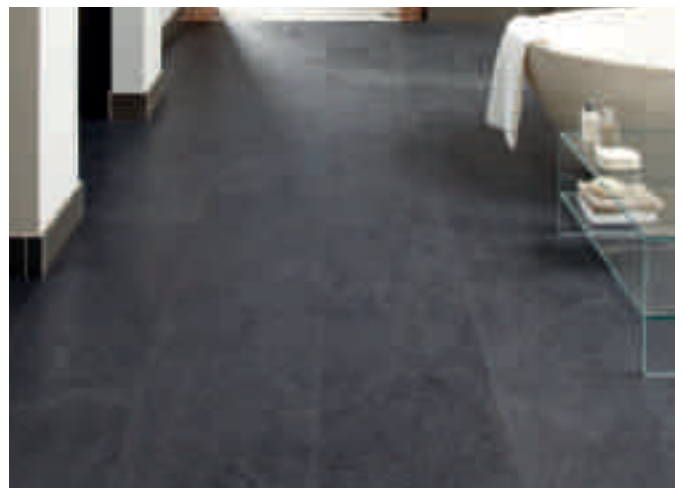

Bathroom

## Howdens Solid Oak and Solid Bamboo Flooring

For those who demand a high quality, natural product, our Solid Oak flooring is the perfect choice. Manufactured from a B/C Grade timber, it is resistant to stains and comes with a 15 year finish and wear guarantee. Alternatively our Solid Bamboo flooring offers a 25 year structural guarantee and a 5 year finish and wear guarantee.

Solid Oak and Solid Bamboo boards can be: secret nailed to timber sub-floors or glued with suitable adhesive (SDH3181, SDH3182 and SDH3176) to solid, dry, flat screeded or concrete sub-floors. Both are fully restorable and will last for many years.

Not suitable for use with underfloor heating.

### Recommended fitting method for timber sub-floors - Secret nail

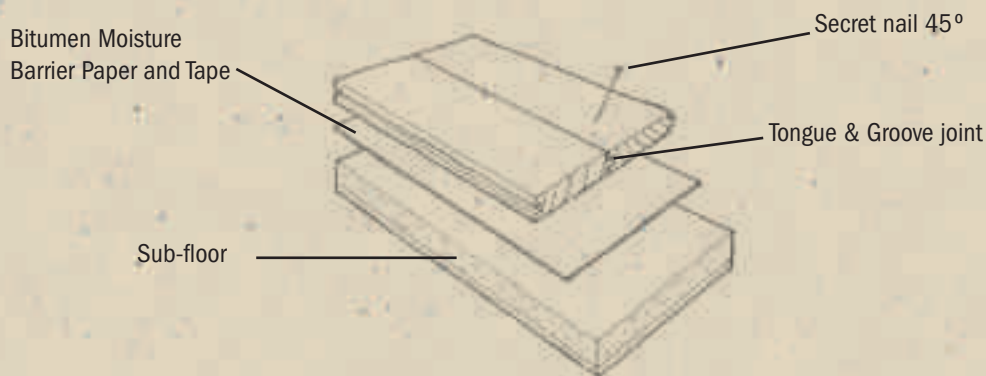

### Recommended fitting method for concrete sub-floors - Glue down

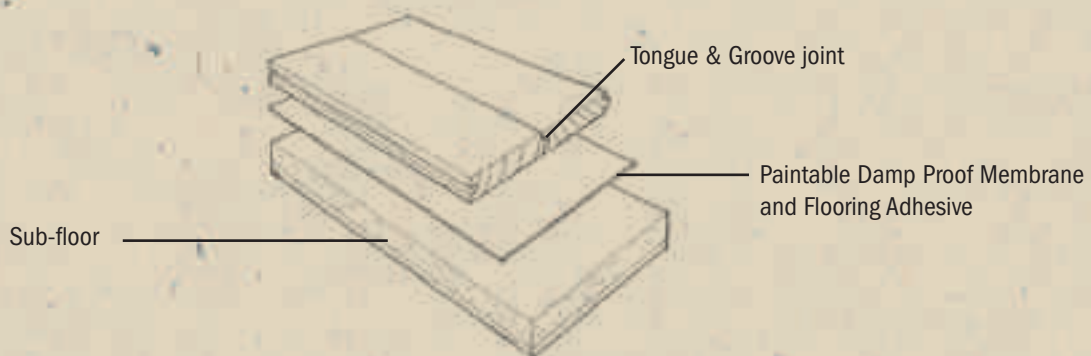

#### Paintable Damp Proof Membrane – SDH0931

Is suitable for use with Howdens Solid Oak and Solid Bamboo floorings on cement based sub-floors. Paintable Damp Proof Membrane is used as a moisture barrier on sub-floors when Damp Proof Membrane (SDH0910) is not suitable. Flooring adhesive can be applied on top of the Paintable Damp Proof Membrane.

#### Bitumen Moisture Barrier Paper – SDH0932

Required when fitting Howdens Solid Oak or Solid Bamboo flooring to a timber based sub-floor. Use in conjunction with Bitumen Moisture Barrier Paper Tape (GAR0410) as the bitumen within the paper forms a seal around the nail.



## Real Wood Flooring

Real Wood (engineered) floors are popular due to their resistance to expansion and contraction from temperature change and moisture.

Engineered Wood is produced using oak veneer layers with each layer oriented in different directions for strength. The top layer can be sanded and re-lacquered up to 3 times. Subject to fitting instructions, Real Wood flooring can be used in conjunction with underfloor heating.

### Recommended fitting method for timber sub-floors - Floating

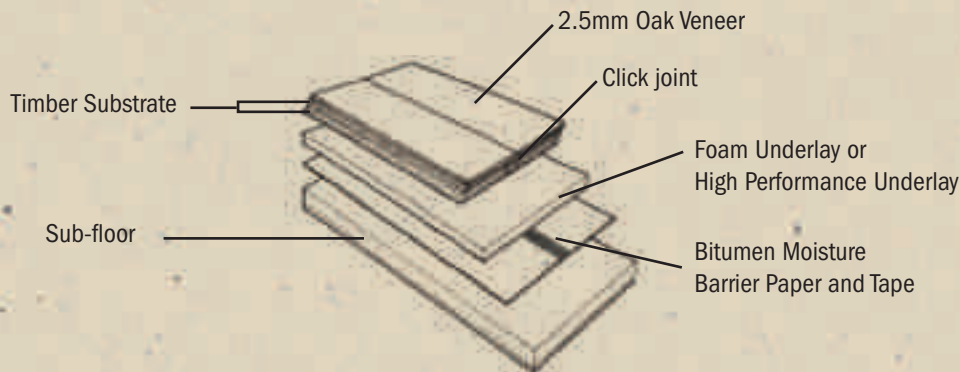

### Recommended fitting method for concrete sub-floors - Floating

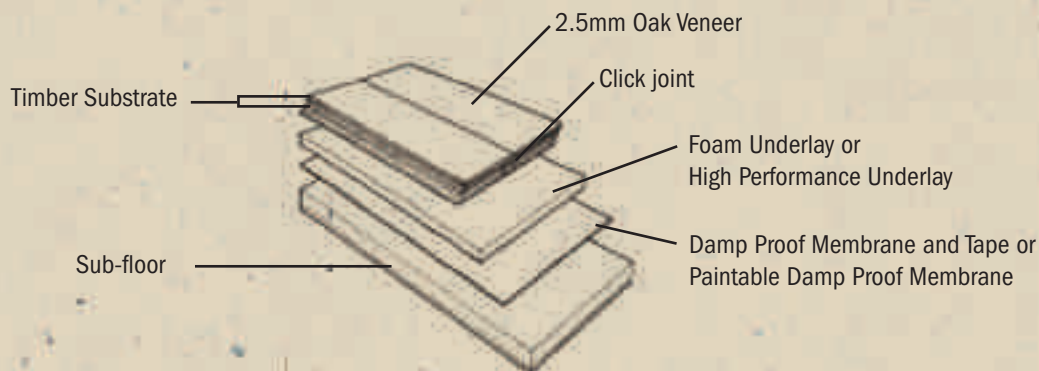

Flooring underlay is essential for use with a floating floor. It provides a cushion for the flooring to sit on, and will provide thermal insulation and reduce the emission and transmission of sound.

#### Foam Underlay – SDH0900

Popular because it is easy to fit, it also has an excellent thermal insulation. Foam Underlay can be used in conjunction with Damp Proof Membrane (SDH0910), Paintable Damp Proof Membrane (SDH0931) or Bitumen Moisture Barrier Paper (SDH0932). Sheets must be joined together using Multi-Purpose Tape (SDH0930).

#### High Performance Underlay (XPS) – SDH0909

This underlay has many benefits including excellent levelling properties, compression strength and impact noise reduction. It is also lightweight and easy to handle. It can be used in conjunction with Damp Proof Membrane (SDH0910), Paintable Damp Proof Membrane (SDH0931) or Bitumen Moisture Barrier Paper (SDH0932).

#### Bitumen Moisture Barrier Paper – SDH0932

Required when fitting Real Wood flooring on a timber based sub-floor. Use in conjunction with Bitumen Moisture Barrier Paper Tape (GAR0410).

#### Damp Proof Membrane – SDH0910

It can be used on stone or concrete sub-floors. Details of where and how to use Damp Proof Membrane can be found in the relevant flooring installation guidelines. Use in conjunction with Multi-Purpose Tape (SDH0930).

#### Paintable Damp Proof Membrane – SDH0931

Is only suitable for use with Howdens Real Wood flooring on concrete based sub-floors. Paintable Damp Proof Membrane is used as a moisture barrier on sub-floors when Damp Proof Membrane (SDH0910) is not suitable.

## Laminate Flooring

Howdens quality laminate flooring has a tried and tested locking system for fast, secure installation. It features a high density fibreboard (HDF) core and edge sealing, which ensure the absolute minimum amount of moisture is absorbed. All our laminate flooring is suitable for use with underfloor heating.

### Recommended fitting method for timber sub-floors - Floating

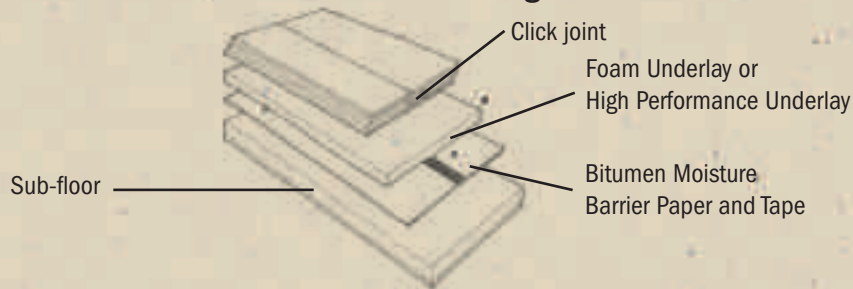

### Recommended fitting method for concrete sub-floors - Floating

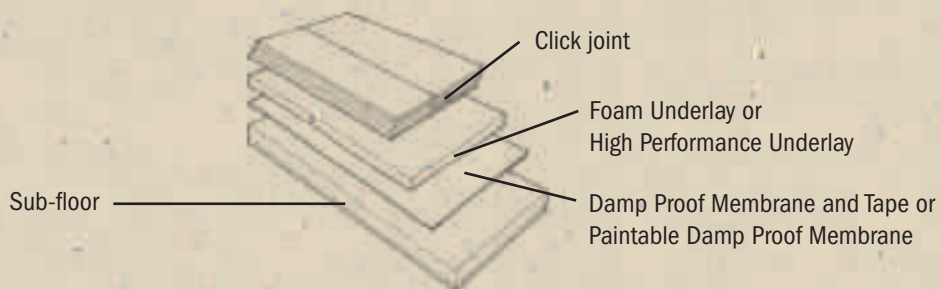

### Aqua Block

On selected ranges, our Aqua Block specification makes the flooring suitable for bathrooms and other areas prone to high moisture levels (excluding wet rooms), if the joints are sealed using Flooring Joint Sealer (SDH0099). Standing water should not be left on any laminate flooring. When cleaning laminate flooring, always ensure where a mop is used that it is well wrung out.

Apply Flooring Joint Sealer along all edges of planks when laying

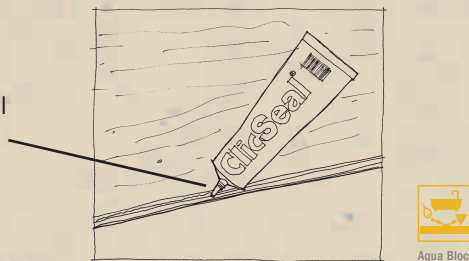

### Laminate Flooring Accessories

Flooring underlay is essential for use with a floating floor. It provides a cushion for the flooring to sit on and will provide thermal insulation and reduce the emission and transmission of sound.

#### Foam Underlay – SDH0900

Popular because it is easy to fit, it also has excellent thermal insulation. Foam Underlay can be used in conjunction with Damp Proof Membrane (SDH0910), Paintable Damp Proof Membrane (SDH0931) or Bitumen Moisture Barrier Paper (SDH0932). Sheets must be joined together using Multi-Purpose Tape (SDH0930).

#### High Performance Underlay (XPS) – SDH0909

This underlay has many benefits including excellent levelling properties, compression strength and impact noise reduction. It is also lightweight and easy to handle. It can be used in conjunction with Damp Proof Membrane (SDH0910), Paintable Damp Proof Membrane (SDH0931) or Bitumen Moisture Barrier Paper (SDH0932).

#### Bitumen Moisture Barrier Paper – SDH0932

Required when fitting laminate flooring on a timber based sub-floor. Use in conjunction with Bitumen Moisture Barrier Paper Tape (GAR0410).

#### Damp Proof Membrane – SDH0910

This can be used on stone or concrete sub-floors. Details of where and how to use Damp Proof Membrane can be found in the relevant flooring installation guidelines. Use in conjunction with Multi-Purpose Tape (SDH0930).

#### Paintable Damp Proof Membrane – SDH0931

Is only suitable for use with laminate flooring on cement based sub-floors. Paintable Damp Proof Membrane is used as a moisture barrier on sub-floors when Damp Proof Membrane (SDH0910) is not suitable.

## Laminate Flooring

### Howdens Professional Fast Fit V Groove

Available in textured and registered embossed finishes, this premium laminate flooring has the natural, authentic look of real wood, enhanced by a four sided V groove.

The quick fit, push down laminate flooring system increases fit speed by up to 30%. The flooring can be laid one piece at a time rather than row by row.

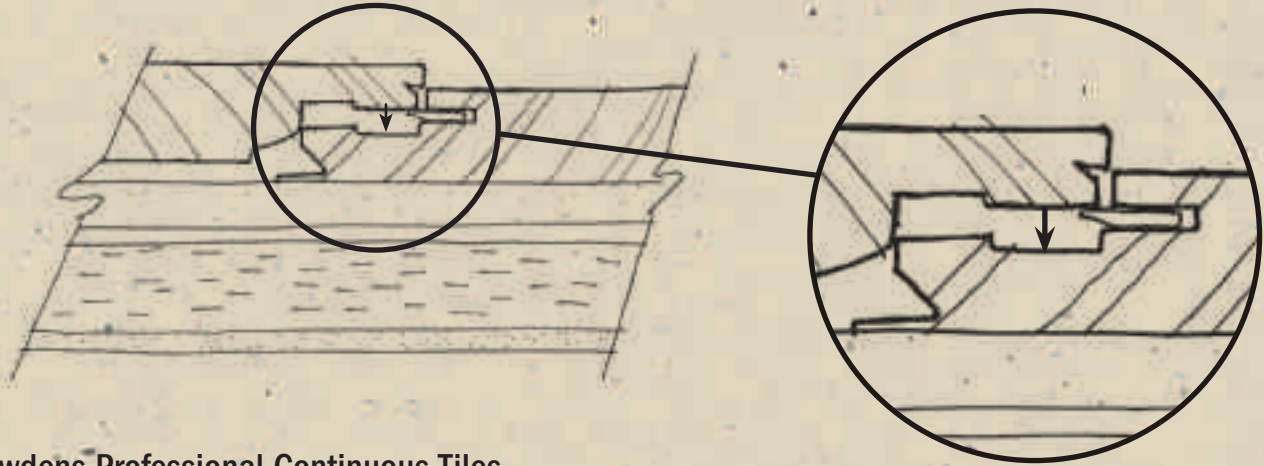

### Howdens Professional Continuous Tiles

Available in a choice of stone or slate finishes, Howdens Professional Continuous Tiles appear almost seamless, with a design that runs across various planks and a finished floor that looks very natural.

Planks are shown below as A, B, C. The arrows indicate the continuous tile effect across the planks.

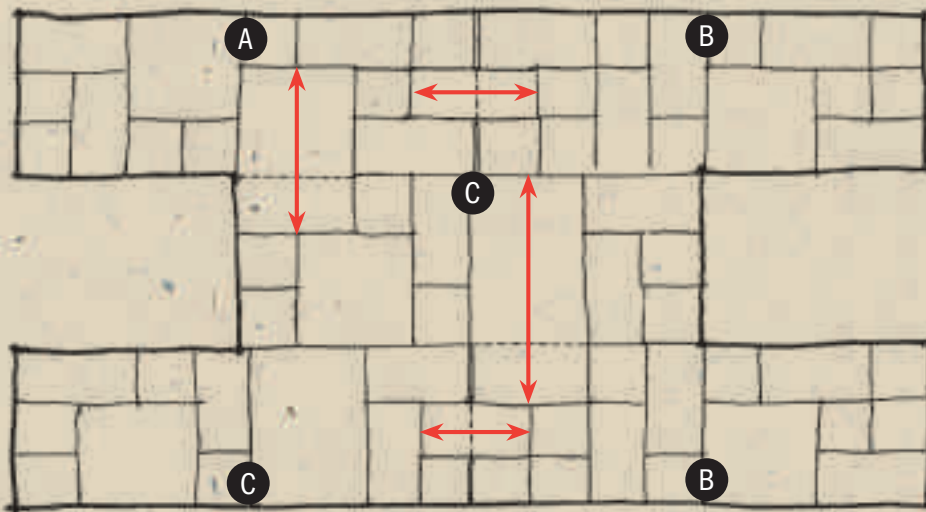

## Flooring Accessories

For a complete installation we offer a range of colour matched laminate and Solid Oak or Solid Bamboo accessories, as detailed below. For further information, please refer to individual product pages.



**L Section** - A finishing strip for use when flooring meets a vertical edge such as a fireplace or step.



**Threshold Strip** - A jointing profile used between 2 floors of the same height or for additional expansion in large areas (please refer to fitting instructions).

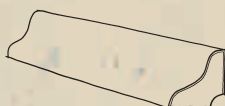

**Scotia** - In situations where skirting is not being replaced, a scotia can be used to cover the expansion gap between the flooring and the skirting.



**Ramp Strip** - A jointing profile used between 2 floors of different heights (please refer to fitting instructions).





Howdens Solid Oak Flooring

## Howdens Solid Oak Flooring

The natural beauty of oak is available in solid bevelled planks. Benefits include greater sound absorption over laminate flooring and warmth underfoot. Varying lengths within each pack create a traditional look. All planks are 18mm thick. Solid Oak flooring is lacquered to give it a polished finish.



15 Year Finish and Wear Guarantee



V Groove



Open Grain



Suitable for use in Kitchens & Living Areas



Fully Restorable

Note: Natural wood products may vary slightly in tone

Not suitable for use in bathrooms, conservatories or with underfloor heating. Flooring should be kept in the room where it will be laid for two weeks or more to allow it to acclimatise to the ambient temperature and humidity.

Suitable for use with Paintable Damp Proof Membrane and Bitumen Moisture Barrier Paper. Please refer to page 06 for more information.



|   |                                |
|---|--------------------------------|
| <a href="#">Pre-Finished Solid Oak (W120mm)</a>                         | <a href="#">P SDH3012/3062</a> |
| <a href="#">Pre-Finished Solid Oak (W140mm)</a>                         | <a href="#">P SDH3013</a>      |
| <a href="#">Pre-Finished Solid Oak (W150mm)</a>                         | <a href="#">P SDH3063</a>      |
| <a href="#">Solid Oak Scotia (L2.1m)</a>                                | <a href="#">SDH3052</a>        |
| <a href="#">Solid Oak Pipe Rose (Pack of 2)</a>                         | <a href="#">UK SDH3090</a>     |
| <a href="#">Solid Oak Threshold Strip (L970mm)</a>                      | <a href="#">P SDH3021</a>      |
| <a href="#">Solid Oak Threshold Strip (L2.1m)</a>                       | <a href="#">P SDH3023</a>      |
| <a href="#">Solid Oak Ramp Strip (L970mm)</a>                           | <a href="#">P SDH3031</a>      |
| <a href="#">Solid Oak L Section (L970mm)</a>                            | <a href="#">P SDH3041</a>      |
| <a href="#">Lumberjack Adhesive Applicator Gun</a>                      | <a href="#">UK SDH3182</a>     |
| <a href="#">Lumberjack Adhesive Pack for Gun (12 x 600ml Cartridge)</a> | <a href="#">UK SDH3181</a>     |
| <a href="#">SikaBond 54 Wood Floor Adhesive (13kg Tub)</a>              | <a href="#">SDH3176</a>        |

Pack Size W120mm: 1.58m/sq

Pack Size W140mm: 1.85m/sq

Pack Size W150mm: 1.98m/sq

## Howdens Solid Bamboo Flooring

Strand woven bamboo is a great alternative to traditional oak. This flooring is both stylish and warm, which makes it a striking feature in any room. Bamboo is hardwearing and environmentally friendly. Bamboo flooring has a matt lacquer finish.



25 Year Structural Guarantee



5 Year Finish and Wear Guarantee



V Groove



Open Grain



Suitable for use in Kitchens & Living Areas



Fully Restorable

Note: Natural wood products may vary slightly in tone

Not suitable for use in bathrooms, conservatories or with underfloor heating. Flooring should be kept in the room where it will be laid for two weeks or more to allow it to acclimatise to the ambient temperature and humidity.

Suitable for use with Paintable Damp Proof Membrane and Bitumen Moisture Barrier Paper. Please refer to page 06 for more information.



|   |                            |
|---|----------------------------|
| <a href="#">Pre-Finished Bamboo (W96mm)</a>                             | <a href="#">SDH4310</a>    |
| <a href="#">Bamboo Scotia (L1.85m)</a>                                  | <a href="#">SDH4314</a>    |
| <a href="#">Bamboo Threshold Strip (L910mm)</a>                         | <a href="#">SDH4311</a>    |
| <a href="#">Bamboo Ramp Strip (L910mm)</a>                              | <a href="#">SDH4312</a>    |
| <a href="#">Bamboo L Section (L910mm)</a>                               | <a href="#">SDH4313</a>    |
| <a href="#">Lumberjack Adhesive Applicator Gun</a>                      | <a href="#">UK SDH3182</a> |
| <a href="#">Lumberjack Adhesive Pack for Gun (12 x 600ml Cartridge)</a> | <a href="#">UK SDH3181</a> |
| <a href="#">SikaBond 54 Wood Floor Adhesive (13kg Tub)</a>              | <a href="#">SDH3176</a>    |

Panel Size: 1.85m x 96mm x 14mm

Pack Size: 1.78m/sq







Howdens Real Wood Oak 3 Strip

# Howdens Real Wood Flooring

The elegant look of engineered flooring can add warmth and character to any room in the home. Real Wood flooring is the perfect choice for the home as it is less reactive to changes in temperature. Our range of Real Wood flooring is available in 3 different profiles; square, micro bevel and V Groove.



Suitable for use in Kitchens & Living Areas



Suitable for use in Conservatories



Suitable for use with Underfloor Heating\*



Fully Restorable

Note: Natural wood products may vary slightly in tone

Not suitable for use in unheated rooms, damp rooms or bathrooms. Flooring should be kept in the room where it will be laid for two weeks or more to allow it to acclimatise to the ambient temperature and humidity.

Suitable for use with Foam Underlay, High Performance Underlay, Damp Proof Membrane, Paintable Damp Proof Membrane and Bitumen Moisture Barrier Paper.

Please refer to page 07 for more information.



|   |                   |
|---|-------------------|
| Pre-Finished Oak Single Plank Wide (W180mm) | <b>P</b> SDH3625  |
| Solid Oak Scotia (L2.1m)                    | SDH3052           |
| Solid Oak Pipe Rose (Pack of 2)             | <b>UK</b> SDH3090 |
| Solid Oak Threshold Strip (L970mm)          | <b>P</b> SDH3021  |
| Solid Oak Threshold Strip (L2.1m)           | <b>P</b> SDH3023  |
| Solid Oak Ramp Strip (L970mm)               | <b>P</b> SDH3031  |
| Solid Oak L Section (L970mm)                | <b>P</b> SDH3041  |

Panel Size: 2.2m x 180mm x 11mm  
Pack Size: 2.38m/sq



|  |                   |
|--|-------------------|
| Pre-Finished Oak Single Plank (W130mm) | SDH3610           |
| Solid Oak Scotia (L2.1m)               | SDH3052           |
| Solid Oak Pipe Rose (Pack of 2)        | <b>UK</b> SDH3090 |
| Solid Oak Threshold Strip (L970mm)     | <b>P</b> SDH3021  |
| Solid Oak Threshold Strip (L2.1m)      | <b>P</b> SDH3023  |
| Solid Oak Ramp Strip (L970mm)          | <b>P</b> SDH3031  |
| Solid Oak L Section (L970mm)           | <b>P</b> SDH3041  |

Panel Size: 2.2m x 130mm x 14mm  
Pack Size: 2.00m/sq

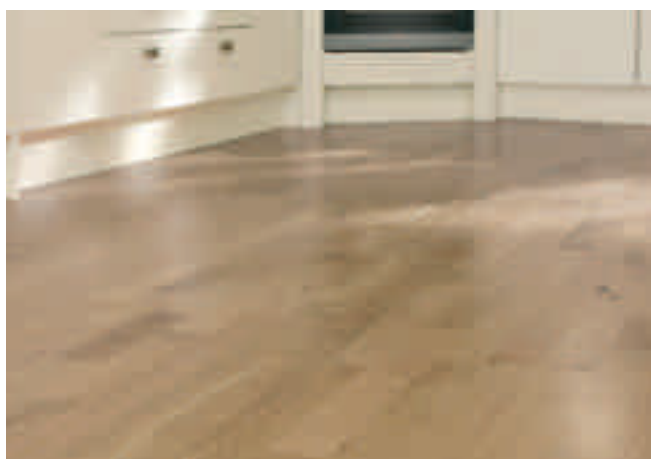

|                                    |                   |
|------------------------------------|-------------------|
| Pre-Finished Oak 3 Strip (W207mm)  | <b>F</b> SDH3215  |
| Solid Oak Scotia (L2.1m)           | SDH3052           |
| Solid Oak Pipe Rose (Pack of 2)    | <b>UK</b> SDH3090 |
| Solid Oak Threshold Strip (L970mm) | <b>P</b> SDH3021  |
| Solid Oak Threshold Strip (L2.1m)  | <b>P</b> SDH3023  |
| Solid Oak Ramp Strip (L970mm)      | <b>P</b> SDH3031  |
| Solid Oak L Section (L970mm)       | <b>P</b> SDH3041  |

Panel Size: 2.2m x 207mm x 14mm  
Pack Size: 3.18m/sq



\*See fitting instructions for maximum temperature





Howdens Professional Fast Fit V Groove Oak



## Howdens Laminate Flooring

The Howdens range of laminate flooring is a comprehensive collection of products for the professional installer. Offering excellent value for money and high quality features, this flooring ensures excellent appearance and performance.

Featuring a glueless click system, the product is easy to install and offers ultimate durability. We can offer the look of real wood and ceramics with the comfort and practicality of a laminate floor.

Howdens laminate flooring is suitable for both domestic and commercial applications. Please refer to specific products for further details.

## Howdens Professional Fast Fit V Groove Flooring

Available in textured and registered embossed finishes, this premium laminate flooring has the natural, authentic look of real wood, enhanced by a four sided V groove. The quick fit, push down laminate flooring system increases fit speed by up to 30%. The flooring can be laid one piece at a time rather than row by row.



20 Year Finish and Wear Guarantee



5 Year Medium Commercial Guarantee



V Groove



Open Grain



Suitable for use in Kitchens & Living Areas



Suitable for use in Conservatories



Suitable for use with Underfloor Heating\*



AC4 Rating



Aqua Block

Suitable for use with Foam Underlay, High Performance Underlay, Damp Proof Membrane, Paintable Damp Proof Membrane and Bitumen Moisture Barrier Paper. Please refer to page 08 for more information.



|                              |                   |
|------------------------------|-------------------|
| Oak (Registered embossed)    | SDH3525           |
| Oak Scotia (L2.4m)           | <b>P</b> SDH4950  |
| Oak Pipe Rose (Pack of 4)    | <b>UK</b> SDH0290 |
| Oak Sealant (310ml)          | SDH0091           |
| Oak Threshold Strip (L900mm) | <b>P</b> SDH4920  |
| Oak Threshold Strip (L2.7m)  | <b>P</b> SDH4921  |
| Oak Ramp Strip (L900mm)      | <b>P</b> SDH4930  |

Panel Size: 1.29m x 192mm x 8mm

Pack Size: 2.22m/sq

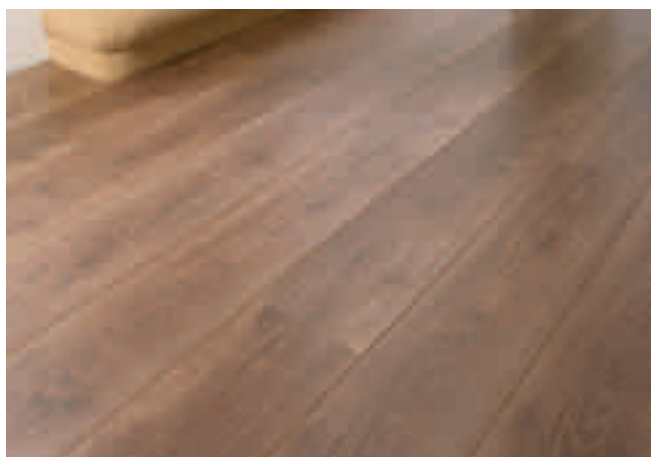

|                                     |                   |
|-------------------------------------|-------------------|
| Rustic Oak (Registered embossed)    | <b>P</b> SDH3526  |
| Rustic Oak Scotia (L2.4m)           | <b>P</b> SDH7350  |
| Rustic Oak Pipe Rose (Pack of 4)    | <b>UK</b> SDH0490 |
| Rustic Oak Sealant (310ml)          | SDH0095           |
| Rustic Oak Threshold Strip (L900mm) | <b>P</b> SDH7320  |
| Rustic Oak Ramp Strip (L900mm)      | <b>P</b> SDH7330  |

Panel Size: 1.29m x 192mm x 8mm

Pack Size: 2.22m/sq

\* See fitting instructions for maximum temperature



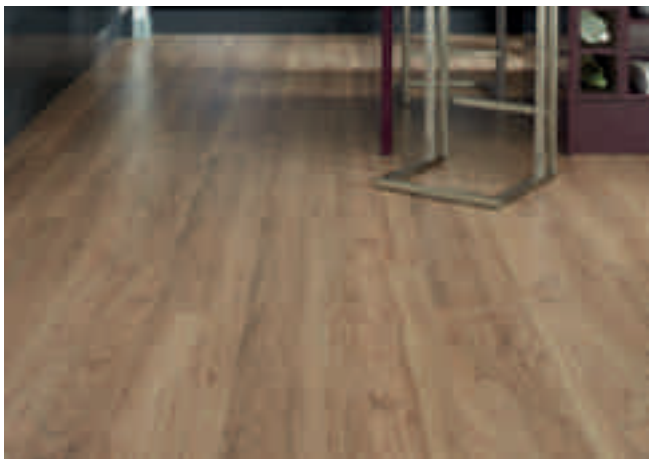

|   |                     |
|---|---------------------|
| American Pecan                          | <b>UK F</b> SDH3528 |
| American Pecan Scotia (L2.4m)           | <b>P</b> SDH7150    |
| American Pecan Pipe Rose (Pack of 4)    | <b>UK</b> SDH0290   |
| American Pecan Sealant (310ml)          | SDH0090             |
| American Pecan Threshold Strip (L900mm) | <b>P</b> SDH7120    |
| American Pecan Ramp Strip (L900mm)      | <b>P</b> SDH7130    |

Panel Size: 1.29m x 192mm x 8mm

Pack Size: 2.22m/sq



|                                       |                   |
|---------------------------------------|-------------------|
| Chestnut Oak (Registered embossed)    | <b>P</b> SDH3529  |
| Chestnut Oak Scotia (L2.4m)           | <b>P</b> SDH7250  |
| Chestnut Oak Pipe Rose (Pack of 4)    | <b>UK</b> SDH0490 |
| Chestnut Oak Sealant (310ml)          | SDH0095           |
| Chestnut Oak Threshold Strip (L900mm) | <b>P</b> SDH7220  |
| Chestnut Oak Ramp Strip (L900mm)      | <b>P</b> SDH7230  |

Panel Size: 1.29m x 192mm x 8mm

Pack Size: 2.22m/sq

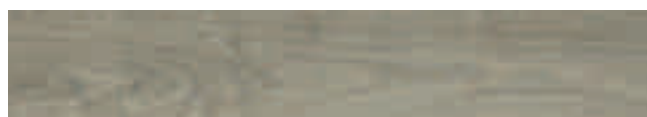

|  |                   |
|--|-------------------|
| Dark Grey Oak                          | <b>P</b> SDH3560  |
| Dark Grey Oak Scotia (L2.4m)           | <b>P</b> SDH6150  |
| Clear Sealant (310ml)                  | <b>UK</b> GAR0106 |
| Dark Grey Oak Threshold Strip (L900mm) | <b>P</b> SDH6120  |
| Dark Grey Oak Ramp Strip (L900mm)      | <b>P</b> SDH6130  |

Panel Size: 1.29m x 192mm x 8mm

Pack Size: 2.22m/sq







|  |                  |
|--|------------------|
| <u>Light Grey Oak (Registered embossed)</u>    | <b>P</b> SDH3561 |
| <u>Light Grey Oak Scotia (L2.4m)</u>           | <b>P</b> SDH6250 |
| <u>Light Grey Sealant (310ml)</u>              | SDH0097          |
| <u>Light Grey Oak Threshold Strip (L900mm)</u> | <b>P</b> SDH6220 |
| <u>Light Grey Oak Ramp Strip (L900mm)</u>      | <b>P</b> SDH6230 |

Panel Size: 1.29m x 192mm x 8mm  
Pack Size: 2.22m/sq



Howdens Professional Fast Fit V Groove Light Grey Oak



Howdens Professional Walnut

# Howdens Professional Flooring

With a textured finish the elegant wood tones of this two strip laminate flooring can be used to create a modern or classic look in a variety of settings.



20 Year Finish and Wear Guarantee



5 Year Medium Commercial Guarantee



Square Profile



2 Strip



Suitable for use in Kitchens & Living Areas



Suitable for use in Conservatories



Suitable for use with Underfloor Heating\*



AC4 Rating



Aqua Block

Suitable for use with Foam Underlay, High Performance Underlay, Damp Proof Membrane, Paintable Damp Proof Membrane and Bitumen Moisture Barrier Paper. Please refer to page 08 for more information.

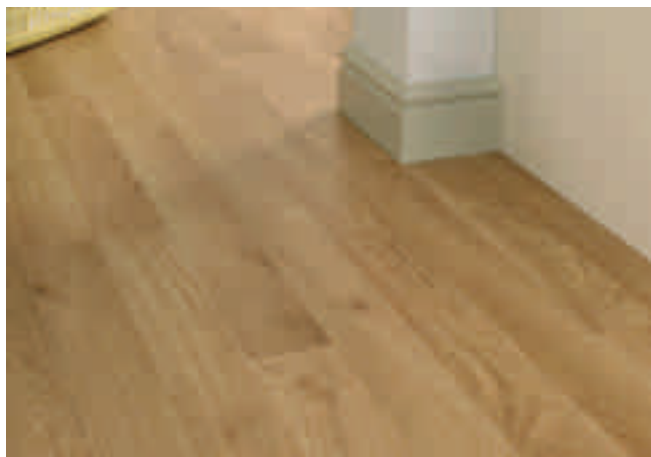

|                              |                     |
|------------------------------|---------------------|
| <b>Oak</b>                   | <b>UK F</b> SDH3552 |
| Oak Scotia (L2.4m)           | <b>P</b> SDH4950    |
| Oak Pipe Rose (Pack of 4)    | <b>UK</b> SDH0290   |
| Oak Sealant (310ml)          | SDH0091             |
| Oak Threshold Strip (L900mm) | <b>P</b> SDH4920    |
| Oak Threshold Strip (L2.7m)  | <b>P</b> SDH4921    |
| Oak Ramp Strip (L900mm)      | <b>P</b> SDH4930    |

Panel Size: 1.29m x 192mm x 8mm

Pack Size: 2.22m/sq



|                                 |                     |
|---------------------------------|---------------------|
| <b>Walnut</b>                   | <b>UK F</b> SDH3550 |
| Walnut Scotia (L2.4m)           | <b>P</b> SDH7350    |
| Walnut Pipe Rose (Pack of 4)    | <b>UK</b> SDH0490   |
| Walnut Sealant (310ml)          | SDH0095             |
| Walnut Threshold Strip (L900mm) | <b>P</b> SDH7320    |
| Walnut Ramp Strip (L900mm)      | <b>P</b> SDH7330    |

Panel Size: 1.29m x 192mm x 8mm

Pack Size: 2.22m/sq

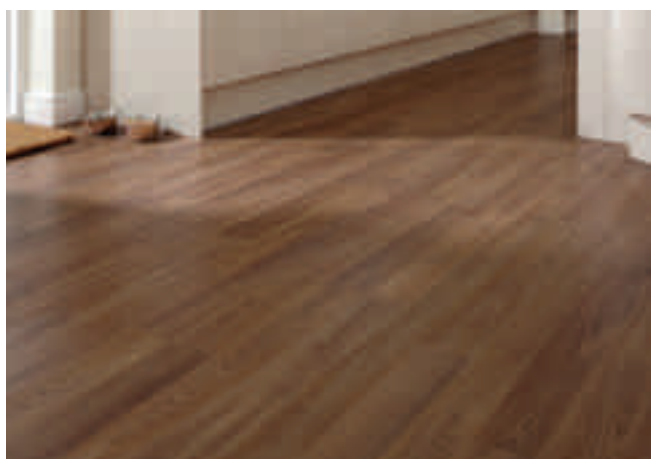

|                                    |                     |
|------------------------------------|---------------------|
| <b>Tudor Oak</b>                   | <b>UK F</b> SDH3551 |
| Tudor Oak Scotia (L2.4m)           | <b>P</b> SDH7250    |
| Tudor Oak Pipe Rose (Pack of 4)    | <b>UK</b> SDH0490   |
| Tudor Oak Sealant (310ml)          | SDH0090             |
| Tudor Oak Threshold Strip (L900mm) | <b>P</b> SDH7220    |
| Tudor Oak Ramp Strip (L900mm)      | <b>P</b> SDH7230    |

Panel Size: 1.29m x 192mm x 8mm

Pack Size: 2.22m/sq

\* See fitting instructions for maximum temperature







Howdens Original Oak

# Howdens Original Flooring

A smooth finish with a choice of decors to enhance any home, Howdens Original laminate is suitable for any location within your property with the exception of bathrooms.



10 Year Finish and Wear Guarantee



5 Year Light Commercial Guarantee



Square Profile



Open Grain



Suitable for use in Kitchens & Living Areas



Suitable for use in Conservatories



Suitable for use with Underfloor Heating\*



AC Rating

Suitable for use with Foam Underlay, High Performance Underlay, Damp Proof Membrane, Paintable Damp Proof Membrane and Bitumen Moisture Barrier Paper. Please refer to page 08 for more information.



|                              |                     |
|------------------------------|---------------------|
| Oak                          | <b>UK F</b> SDH3565 |
| Oak Scotia (L2.4m)           | <b>P</b> SDH8050    |
| Oak Pipe Rose (Pack of 4)    | <b>UK</b> SDH0290   |
| Oak Sealant (310ml)          | SDH0091             |
| Oak Threshold Strip (L900mm) | <b>P</b> SDH8020    |
| Oak Threshold Strip (L2.7m)  | <b>P</b> SDH8021    |
| Oak Ramp Strip (L900mm)      | <b>P</b> SDH8030    |

Panel Size: 1.29m x 192mm x 7mm

Pack Size: 2.47m/sq



|                                   |                     |
|-----------------------------------|---------------------|
| Dark Oak                          | <b>UK F</b> SDH3567 |
| Dark Oak Scotia (L2.4m)           | <b>P</b> SDH7350    |
| Dark Oak Pipe Rose (Pack of 4)    | <b>UK</b> SDH0490   |
| Dark Oak Sealant (310ml)          | SDH0095             |
| Dark Oak Threshold Strip (L900mm) | <b>P</b> SDH7120    |
| Dark Oak Ramp Strip (L900mm)      | <b>P</b> SDH7130    |

Panel Size: 1.29m x 192mm x 7mm

Pack Size: 2.47m/sq

\*See fitting instructions for maximum temperature







Howdens Oak

# Howdens Flooring

This laminate flooring has a smooth finish. Suitable for any location within your property with the exception of bathrooms.

|   |   |   |   |   |   |
|---|---|---|---|---|---|
|  |  |  |  |  |  |
| Square Profile  | 3 Strip   | Suitable for use in Kitchens & Living Areas                                       | Suitable for use in Conservatories  | Suitable for use with Underfloor Heating*   | AC Rating   |

Suitable for use with Foam Underlay, High Performance Underlay, Damp Proof Membrane, Paintable Damp Proof Membrane and Bitumen Moisture Barrier Paper. Please refer to page 08 for more information.



|                              |                   |
|------------------------------|-------------------|
| <b>Oak</b>                   | <b>P</b> SDH2096  |
| Oak Scotia (L2.4m)           | <b>P</b> SDH7450  |
| Oak Pipe Rose (Pack of 4)    | <b>UK</b> SDH0290 |
| Oak Sealant (310ml)          | SDH0091           |
| Oak Threshold Strip (L900mm) | <b>P</b> SDH7420  |
| Oak Ramp Strip (L900mm)      | <b>P</b> SDH7430  |

Panel Size: 1.29m x 193mm x 6mm  
Pack Size: 2.99m/sq

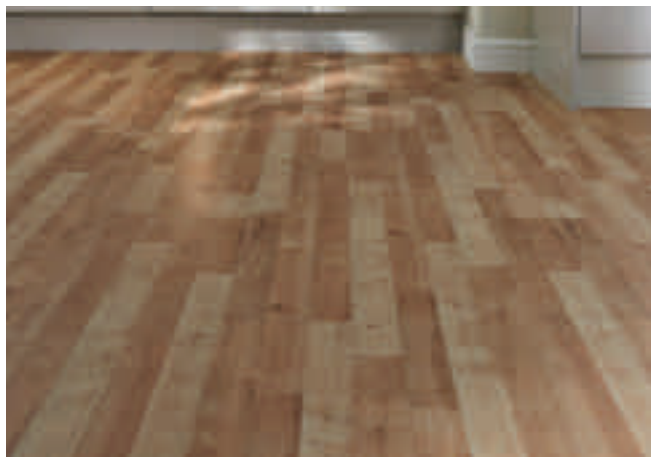

|                                     |                     |
|-------------------------------------|---------------------|
| <b>Rustic Oak</b>                   | <b>UK F</b> SDH2092 |
| Rustic Oak Scotia (L2.4m)           | <b>P</b> SDH8050    |
| Rustic Oak Pipe Rose (Pack of 4)    | <b>UK</b> SDH0490   |
| Rustic Oak Sealant (310ml)          | SDH0091             |
| Rustic Oak Threshold Strip (L900mm) | <b>P</b> SDH8020    |
| Rustic Oak Threshold Strip (L2.7m)  | <b>P</b> SDH8021    |
| Rustic Oak Ramp Strip (L900mm)      | <b>P</b> SDH8030    |

Panel Size: 1.29m x 195mm x 6mm  
Pack Size: 2.50m/sq



\*See fitting instructions for maximum temperature





Howdens Professional Continuous Light Stone Tile

# Howdens Professional Continuous Tiles

The registered embossed finish is designed to give the appearance of a natural stone or slate floor. The joins in this laminate tile are almost seamless, resulting in a floor that looks very natural.

|   |   |  |  |   |  |   |   |
|---|---|--|--|---|--|---|---|
| <br>30 Year<br>Finish<br>and Wear<br>Guarantee | <br>5 Year<br>Medium to Heavy<br>Commercial<br>Guarantee | <br>Continuous<br>Pattern | <br>Suitable for<br>use in Kitchens<br>& Living Areas | <br>Suitable for<br>use in<br>Conservatories | <br>Suitable for use<br>with Underfloor<br>Heating* | <br>AC5 Rating | <br>Aqua Block |
|---|---|--|--|---|--|---|---|

Suitable for use with Foam Underlay, High Performance Underlay, Damp Proof Membrane, Paintable Damp Proof Membrane and Bitumen Moisture Barrier Paper. Please refer to page 08 for more information.



**Natural Stone** (Registered embossed) **P** SDH2082  
Clear Sealant (310ml) **UK** GAR0106

Tile Size: 1.18mm x 395mm x 8mm  
Pack Size: 2.32m/sq



**Black Slate** (Registered embossed) **P** SDH2084  
Black Scotia (L2.4m) **P** SDH7950  
Clear Sealant (310ml) **UK** GAR0106  
Black Threshold Strip (L2.4m) **P** SDH7920  
Black Ramp Strip (L2.4m) **P** SDH7930  
Black Skirting (L2.4m) MOD0540

Tile Size: 1.18m x 395mm x 8mm  
Pack Size: 2.32m/sq



**Limestone** (Registered embossed) **P** SDH2083  
Clear Sealant (310ml) **UK** GAR0106

Tile Size: 1.18m x 395mm x 8mm  
Pack Size: 2.32m/sq



**Light Stone** (Registered embossed) **P** SDH2088  
Clear Sealant (310ml) **UK** GAR0106

Tile Size: 1.18m x 395mm x 8mm  
Pack Size: 2.32m/sq

\*See fitting instructions for maximum temperature







Howdens Professional Fast Fit V Groove Basalt Slate Tile

## Howdens Professional Fast Fit V Groove Tiles

Available in textured and smooth finishes, this laminate product offers an alternative to slate, stone and ceramic tiles. This product is ideal for kitchens, giving warmth underfoot with practicality and easy maintenance. The quick fit, push down laminate flooring system increases fit speed by up to 30%.



20 Year Finish and Wear Guarantee



5 Year Medium Commercial Guarantee



V Groove



2 Tile



Suitable for use in Kitchens & Living Areas



Suitable for use in Conservatories



Suitable for use with Underfloor Heating\*



AC4 Rating



Aqua Block

Suitable for use with Foam Underlay, High Performance Underlay, Damp Proof Membrane, Paintable Damp Proof Membrane and Bitumen Moisture Barrier Paper. Please refer to page 08 for more information.

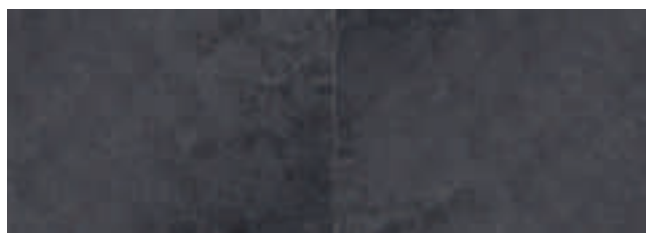
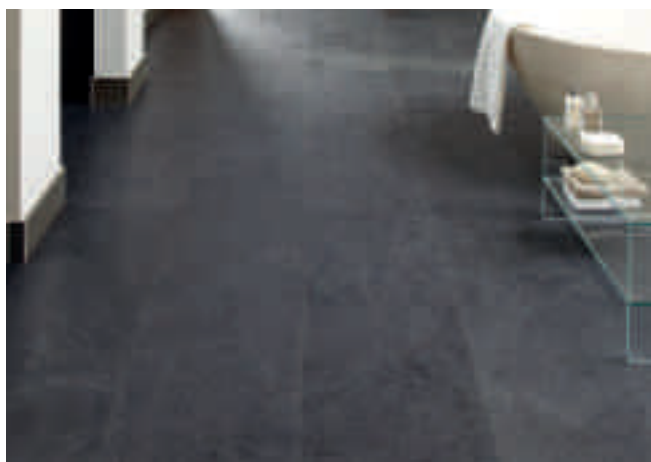

|                               |            |
|-------------------------------|------------|
| Basalt Slate                  | P SDH3662  |
| Black Scotia (L2.4m)          | P SDH7950  |
| Clear Sealant (310ml)         | UK GAR0106 |
| Black Threshold Strip (L2.4m) | P SDH7920  |
| Black Ramp Strip (L2.4m)      | P SDH7930  |
| Black Skirting (L2.4m)        | MOD0540    |

Tile Size: 1.29m x 327mm x 8mm

Pack Size: 2.52m/sq

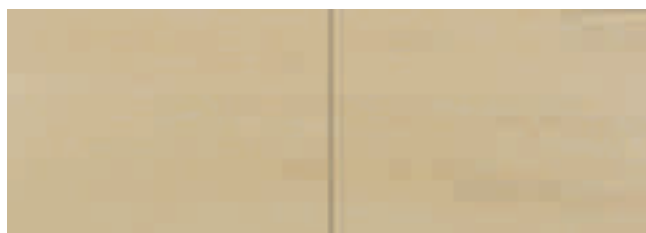

|                       |            |
|-----------------------|------------|
| Travertine            | P SDH3663  |
| Clear Sealant (310ml) | UK GAR0106 |

Tile Size: 1.29m x 327mm x 8mm

Pack Size: 2.52m/sq

\*See fitting instructions for maximum temperature



# Howdens Professional Random Effect Tile

This random effect tile is textured and offers a realistic slate finish, which is suitable for a variety of locations in your property.



20 Year  
Finish  
and Wear  
Guarantee



5 Year  
Medium  
Commercial  
Guarantee



Square Profile



Random  
Pattern



Suitable for  
use in Kitchens  
& Living Areas



Suitable for  
use in  
Conservatories



Suitable for use  
with Underfloor  
Heating\*



AC Rating



Aqua Block

Suitable for use with Foam Underlay, High Performance Underlay, Damp Proof Membrane, Paintable Damp Proof Membrane and Bitumen Moisture Barrier Paper. Please refer to page 08 for more information.



|                               |            |
|-------------------------------|------------|
| Slate                         | P SDH3650  |
| Black Scotia (L2.4m)          | P SDH7950  |
| Clear Sealant (310ml)         | UK GAR0106 |
| Black Threshold Strip (L2.4m) | P SDH7920  |
| Black Ramp Strip (L2.4m)      | P SDH7930  |
| Black Skirting (L2.4m)        | MOD0540    |

Tile Size: 1.29m x 326mm x 8mm

Pack Size: 2.53m/sq

\*See fitting instructions for maximum temperature





Howdens Professional Random Effect Slate Tile



## Flooring Specifications

---

Please see below flooring specifications, providing an essential guide on how to buy flooring specific for your needs.

### Characteristics of Howdens flooring



#### V Groove

Planks have micro to deep bevelled edges to create a V Groove.



#### Continuous Pattern

Gives the appearance of a natural stone or slate floor with seamless joins.



#### Square Profile

Square profiled planks create a seamless look.



#### Random Pattern

Offers a realistic slate finish.



#### Open Grain

Replicates the look of solid wood flooring.



#### Suitable for use in Kitchens & Living Areas

Flooring can be laid in various rooms throughout the home.



#### 2 Strip

This 2 strip plank creates a feeling of space.



#### Suitable for use in Conservatories

Flooring is less sensitive to changes in temperature.



#### 3 Strip

This 3 strip plank creates a feeling of space.



#### Suitable for use with Underfloor Heating

See fitting instructions for maximum temperature.



#### 2 Tile

Provides an authentic look of real tiles.



#### Fully Restorable

Flooring can be restored to capture the finish and performance of the product when first installed. Real Wood flooring can be re-finished up to 3 times.

### Laminate Flooring Classification - Abrasion Classification (AC) Rating

---

The AC Rating tests the durability levels of laminate flooring.



Suitable for heavy domestic/light commercial use.



Suitable for medium commercial use.



Suitable for medium to heavy commercial use.

AC4 and AC5 laminates can be used for domestic use, however please be aware that as the ranking increases the roughness of the flooring also increases.

### Aqua Block Specifications

---



Aqua Block

The Aqua Block logo indicates that when joints are sealed using Flooring Joint Sealer (SDH0099), this flooring is suitable for use in bathrooms and other areas prone to high moisture levels (excluding wet rooms).

# Flooring Care & Maintenance Guide

## All flooring types

Care and regular maintenance/cleaning will ensure flooring lasts for many years. Below are some helpful tips to maintain flooring:

- Use a soft brush or vacuum cleaner to remove any surface dust. Do not use abrasive cleaners, steel wool or scouring pads, as they will damage the floor
- For regular cleaning use a cloth, ensuring it is well wrung. It is important not to apply excess moisture to the floor
- Do not use steam mops/cleaners
- We recommend the use of felt pads under furniture to protect the floor. Moveable furniture/chairs should be on soft castors or placed on a plastic mat. Any single piece of furniture placed on the floor should not exceed 115kgs in weight
- Door mats should be used inside and outside all external doorways to prevent grit from being carried across flooring, to protect surfaces from excessive wear and tear

## Re-lacquering of Solid & Real Wood flooring

Over time, the lacquered surface of Solid and Real Wood flooring will wear. When this happens, flooring can be restored in order to capture the finish and performance of the product when first installed.

We recommend that Real Wood flooring is not re-finished more than 3 times.

### 1. Surface Preparation

Remove the existing layer of varnish with a disk sander and extract/clear any dust

### 2. Finishing

Finish with suitable flooring varnish/lacquer. Always follow the varnish/lacquer manufacturer's instructions. We recommend testing the finish on a hidden area or off cut, before applying to the full floor



Howdens Real Wood Oak Single Plank Wide (W180mm)



Howdens Professional Continuous Natural Stone Tile



Howdens Professional Tudor Oak

## Flooring Accessories & Tools

Howdens supplies a variety of flooring accessories and tools for a professionally fitted floor. The right underlay is essential for use with floating floors. It provides thermal insulation and reduces the transmission of sound. A damp proof membrane can be used on stone or concrete based sub-floors before laying the underlay. Use flooring spacers around the edge of the floor to allow a gap for expansion and contraction, colour matched scotias can then be used to cover the gaps left around the edge.

### Underlay & Moisture Barrier



**Foam Underlay** 1m x 15m x 2mm **UK** SDH0900  
**Multi-Purpose Tape** 50m x 50mm SDH0930  
 Suitable for use with Howdens Real Wood flooring and Howdens Laminate flooring



**High Performance Underlay (XPS)** 1m x 600mm x 5mm **UK** SDH0909  
 Suitable for use with Howdens Real Wood flooring and Howdens Laminate flooring



**Damp Proof Membrane** 3m x 4m x 0.2mm **UK** SDH0910  
**Multi-Purpose Tape** 50m x 50mm SDH0930  
 Suitable for use with Howdens Real Wood flooring and Howdens Laminate flooring on concrete sub-floors



**Paintable Damp Proof Membrane** 5 Litres **UK** SDH0931  
 Suitable for use on concrete based sub-floors only



**Bitumen Moisture Barrier Paper** 1m x 25m **UK** SDH0932  
**Bitumen Moisture Barrier Paper Tape** 45m x 75mm GAR0410  
 Suitable for use on timber based sub-floors only



## Hardwood Threshold Strips

Howdens Joinery hardwood threshold strips are available in either a chamfered or square profile. They are ideal for replacing thresholds and supplied unfinished, allowing them to be painted or varnished to exact requirements.



**Chamfered Internal Hardwood Threshold Strip**

Suitable for use with different types of flooring fitted to the same height between a wider door frame

900mm x 140mm x 18mm

**UK F** SDH0959

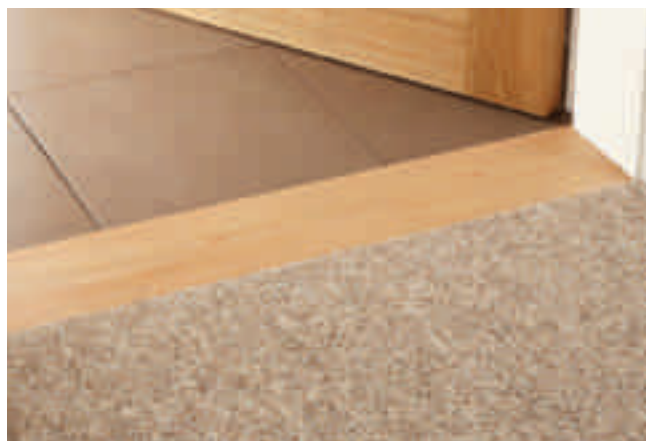

**Square Profile Internal Hardwood Threshold Strip**

Suitable for use with different types of flooring fitted to the same height between a wider door frame

900mm x 140mm x 18mm

**UK F** SDH0958

## Floor Profiles

For a complete installation, Howdens offer a range of aluminium and redwood floor profiles in addition to a range of colour matched accessories. For more information please refer to product ranges.



**White Scotia L2.4m**

**P** SDH0961

**Redwood Scotia L2.4m**

**UK P** MOD0711

Colour matched scotia available in other ranges

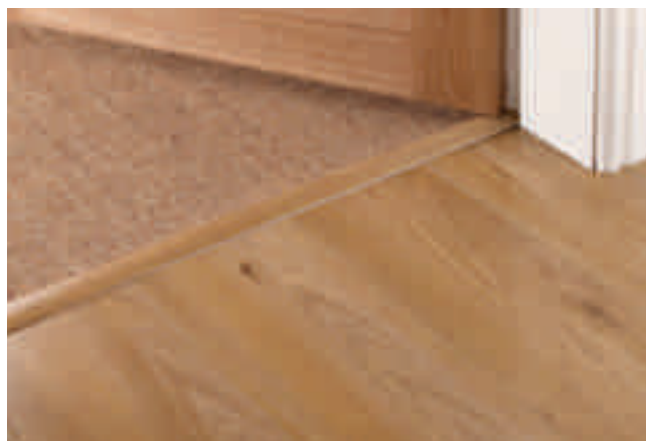

**Ramp Strip**

Sold by range



**Threshold Strip**

Sold by range



**L Section**

Sold by range



## Floor Profiles



**Chrome Effect Pipe Rose (Pack of 4)** SDH0895  
Coloured matched pipe rose available in other ranges



**White Pipe Rose (Pack of 4)** UK SDH0896  
Coloured matched pipe rose available in other ranges



**Profile A - L2.7m x W32mm Laminate to Laminate**  
Suitable for use from laminate to laminate, this profile will also bridge differences in height up to 6mm  
**Aluminium** SDH0940



**Profile B - L2.7m x W38mm Laminate to Carpet or Linoleum**  
Suitable for use from laminate to carpet or linoleum, this profile will also bridge differences in height of between 4mm to 15mm  
**Aluminium** SDH0942



**Profile F - L2.7m x W30mm Edge Profile for Flooring 7mm to 9mm**  
This profile is designed to professionally finish laminate floors  
**Aluminium** SDH0945

## Redwood Mouldings



**Quadrant 16mm x 16mm x L2.4m** UK P MOD0710



**Angle 20mm x 20mm x L2.4m** UK P MOD0712

## Sealants & Adhesives



**Sealant (310ml)**

Sold by range



**Lumberjack Adhesive Applicator Gun**

**UK** SDH3182

**Lumberjack Adhesive Pack for Gun (12 x 600ml cartridges)**

**UK** SDH3181

Suitable for use with Howdens Solid Oak and Howdens Solid Bamboo flooring



**SikaBond 54 Wood Floor Adhesive (13kg tub)**

**SDH3176**

Suitable for use with Howdens Solid Oak and Howdens Solid Bamboo flooring



## Flooring Tools



Laminate Flooring Fitting Kit SDH0970  
 Flooring Spacers (Pack of 20) SDH0980



Heavy Duty Pull Bar SDH9011



Knocking Block UK SDH9010



Flooring Adhesive Trowel SDH0912



Flooring Joint Sealer (125ml) SDH0099



Flooring Care Kit SDH0715  
 Suitable for timber and timber effect flooring



Aqua Block





Bitumen Moisture Barrier Paper & Tape



Black Scotia



Chrome Effect Pipe Rose



Chamfered Internal Hardwood Threshold Strip



Sealants

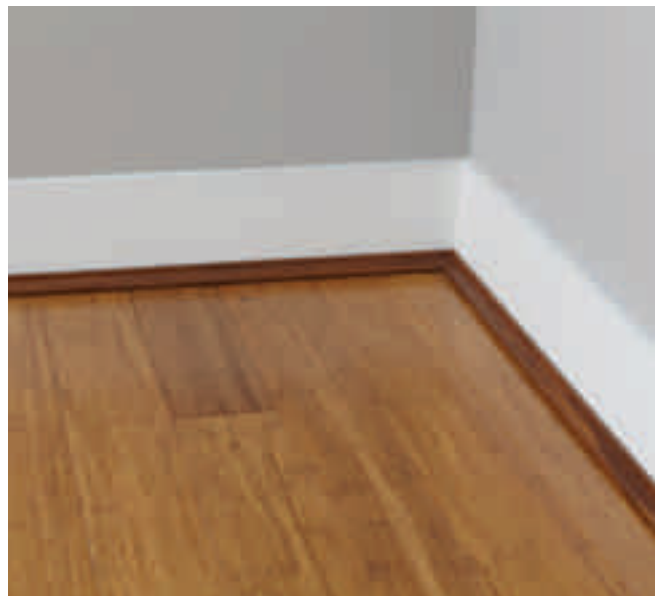

Bamboo Scotia



## Matching Flooring & Worktop Combinations

---

Several of Howdens flooring ranges are available with matching worktops, so you can create a complementary style throughout your kitchen.



**Flooring** - Howdens Solid Oak 120mm Wide **Worktop** - Solid Oak Block 40mm



**Flooring** - Howdens Professional Fast Fit V Groove American Pecan **Worktop** - American Pecan Square Edged



**Flooring** - Howdens Professional Continuous Natural Stone Tile **Worktop** - Natural Stone Tan Square Edged



**Flooring** - Howdens Professional Fast Fit V Groove Basalt Slate Tile **Worktop** - Basalt Slate Honed Square Edged



**Flooring** - Howdens Professional Oak **Worktop** - Oak Block Style Square Edged



**Flooring** - Howdens Professional Walnut **Worktop** - Walnut Block Style Matt Laminated

## Mouldings

The Howdens range includes a number of moulding options to suit your individual requirements. The timber mouldings are manufactured from high-grade Scandinavian Redwood or prefinished Solid Oak and the MDF products are available either primed or with an oak veneer.

For full details please refer to The Joinery Collection brochure or visit our website at [www.howdens.com](http://www.howdens.com)



Primed Pencil Round Skirting and Architrave



Ogee Skirting and Architrave



Burford Oak Veneered Traditional Skirting and Architrave

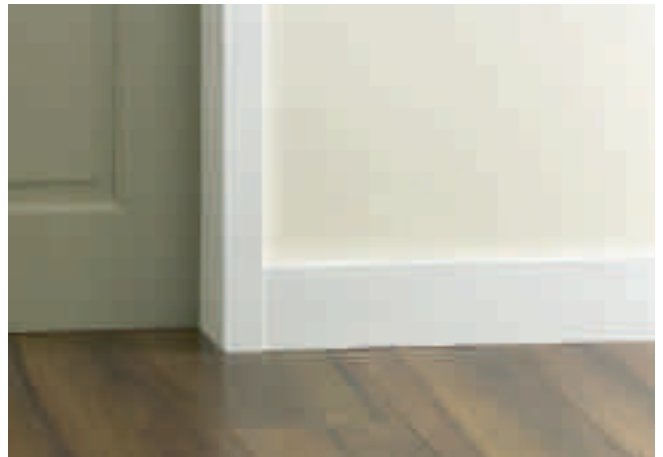

Primed Square Skirting and Architrave

## Scotias

Howdens offer colour matched scotias in 13 different finishes, including oak, bamboo, walnut, black and white. Scotias are used to cover the expansion gap between the flooring and skirting, in situations where skirting is not being replaced.

For full details please refer to the The Joinery Collection brochure or visit our website at [www.howdens.com](http://www.howdens.com)

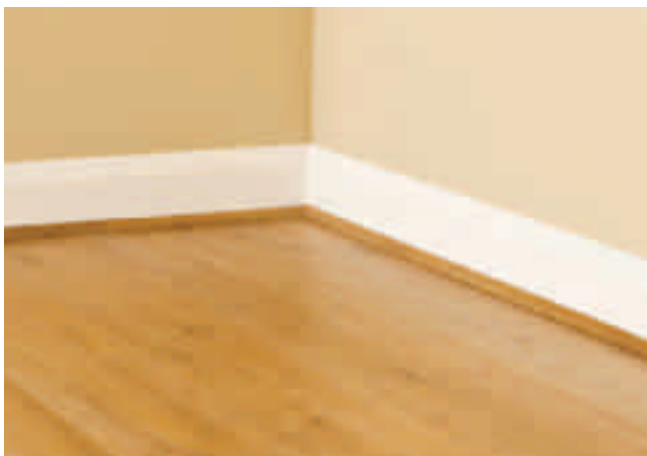

Oak Scotia

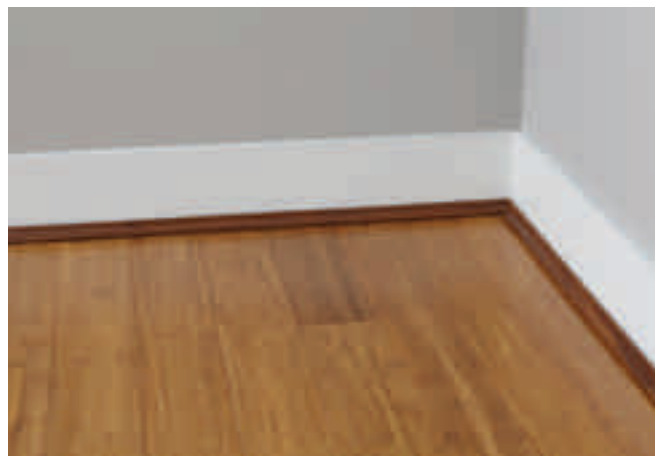

Bamboo Scotia



# The Complete Howdens Collection

Howdens Joinery offers a range of integrated kitchen and joinery products designed to meet the needs of modern living. Our offer includes over 40 different kitchen designs, plus a full range of accessories, worktops, sinks, taps, doors, flooring, skirting and a wide variety of Lamona appliances exclusive to Howdens.

We are a trade only business that has been selling to trade professionals since 1995. Given the complexity of the modern kitchen we believe that only experienced, qualified builders and joiners should install our products.

- We offer you the reassurance that Howdens is a market leader. Last year we supplied over 350,000 kitchens to UK homes.
- There are over 580 Howdens depots nationwide so it's likely we are local to you. And because we are local, your builder can collect exactly what he needs, when he needs it, to install your dream kitchen.
- Each of our depots has experienced designers who will plan your kitchen and be on hand throughout to help you and your builder.

For more information, please request any of the following brochures from your local builder or visit [www.howdens.com](http://www.howdens.com)

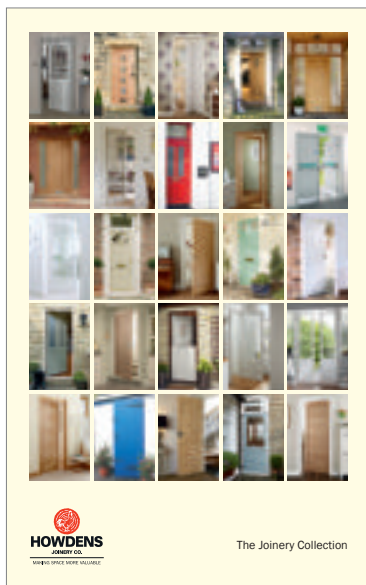

The Joinery Collection

**The Joinery Collection**



The Hardware Collection

**The Hardware Collection**

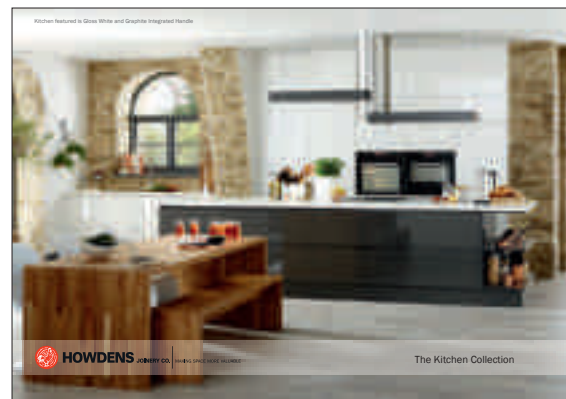

The Kitchen Collection

**The Kitchen Collection**



The Appliance, Sink & Tap Collection

**The Appliance, Sink & Tap Collection**



**The Bathroom Cabinet Collection**





Howdens Solid Bamboo



Howdens Professional Fast Fit V Groove American Pecan



Howdens Professional Natural Stone Continuous Tile

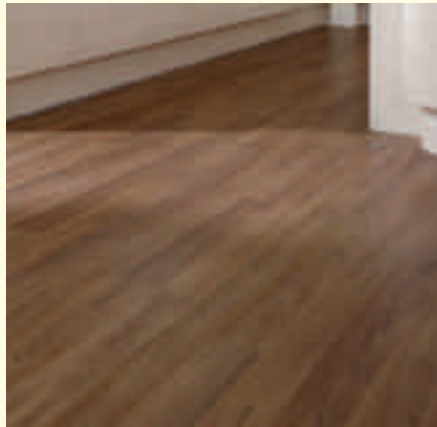

Howdens Professional Tudor Oak



Howdens Original Oak

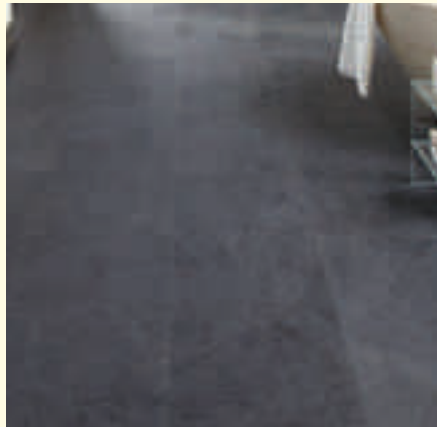

Howdens Professional Fast Fit V Groove Basalt Slate Tile



**HOWDENS JOINERY CO.** MAKING SPACE MORE VALUABLE

November 2014 ISSUE (XBR8413)

Howden Joinery Ltd, First Floor, 40 Portman Square, London, W1H 6LT.

Registered in England 526923

[www.howdens.com](http://www.howdens.com)



This brochure is printed on FSC® certified paper

Product information correct at the time of publication in November 2014. The company has a policy of continuous product development and reserves the right to change any products and specifications given in this brochure. Subject to the Terms and Conditions of Trading, a copy of the Howdens Joinery Terms and Conditions is available upon request. Photography is for illustration purposes only, some products may differ from those shown. The colours in this brochure are as accurate as printing processes allow. Many of the products used in the photography of this brochure have been donated to local community projects.